

**QUICK MOLD CHANGE SYSTEM**  
快速換模/台車系統

*Constant Innovation*

[www.sandsun.com.tw](http://www.sandsun.com.tw)



**MANAGING PHILOSOPHY**  
Moderate & Reliable Aggressive & Creative  
Demanding for Perfection Constant Operation

**QUALITY POLICY**  
Quality Stability Customer Satisfaction

**經營理念**  
穩健踏實 精進創新 止於至善 永續經營

**品質政策**  
品質穩定 客戶肯定

**山田順精機股份有限公司**  
SANDSUN PRECISION MACHINERY CO.,LTD.  
台灣省彰化縣大村鄉中山路三段57巷7號  
NO.7, LANE 57, SEC.3, CHUNG-SHAN RD., DAH-TSUEN,  
CHANG-HWA, TAIWAN.  
E-mail:sa2@sandsun.com.tw (台灣)  
sa3@sandsun.com.tw (abroad)  
sa4@sandsun.com.tw (abroad)  
TEL:+886-4-8536688 FAX:+886-4-8536699

**山田順精密機械(蘇州)有限公司**  
SANDSUN PRECISION MACHINERY (SUZHOU) CO.,LTD.  
江蘇省蘇州市吳中區角直鎮楓庄路  
FENGZHUANG ROAD, LUZHI TOWN, WUZHONG DISTRICT,  
SUZHOU CITY, JIANGSU, CHINA  
E-mail:sandsun\_sz@126.com  
TEL:0512-66026635 FAX:0512-66026637



**壓鑄機**  
DIE CASTING MACHINE

**射出成型機**  
INJECTION MOLDING MACHINE

**中空成型機**  
BLOW MOLDING MACHINE



## QUICK MOLD CHANGE SYSTEM

It is an era for making high frequency mold change with multiple patterns and small quantity. In order to save time for the mold change and ensure the safety of the operation, it is just in time to apply Quick Mold Change System.

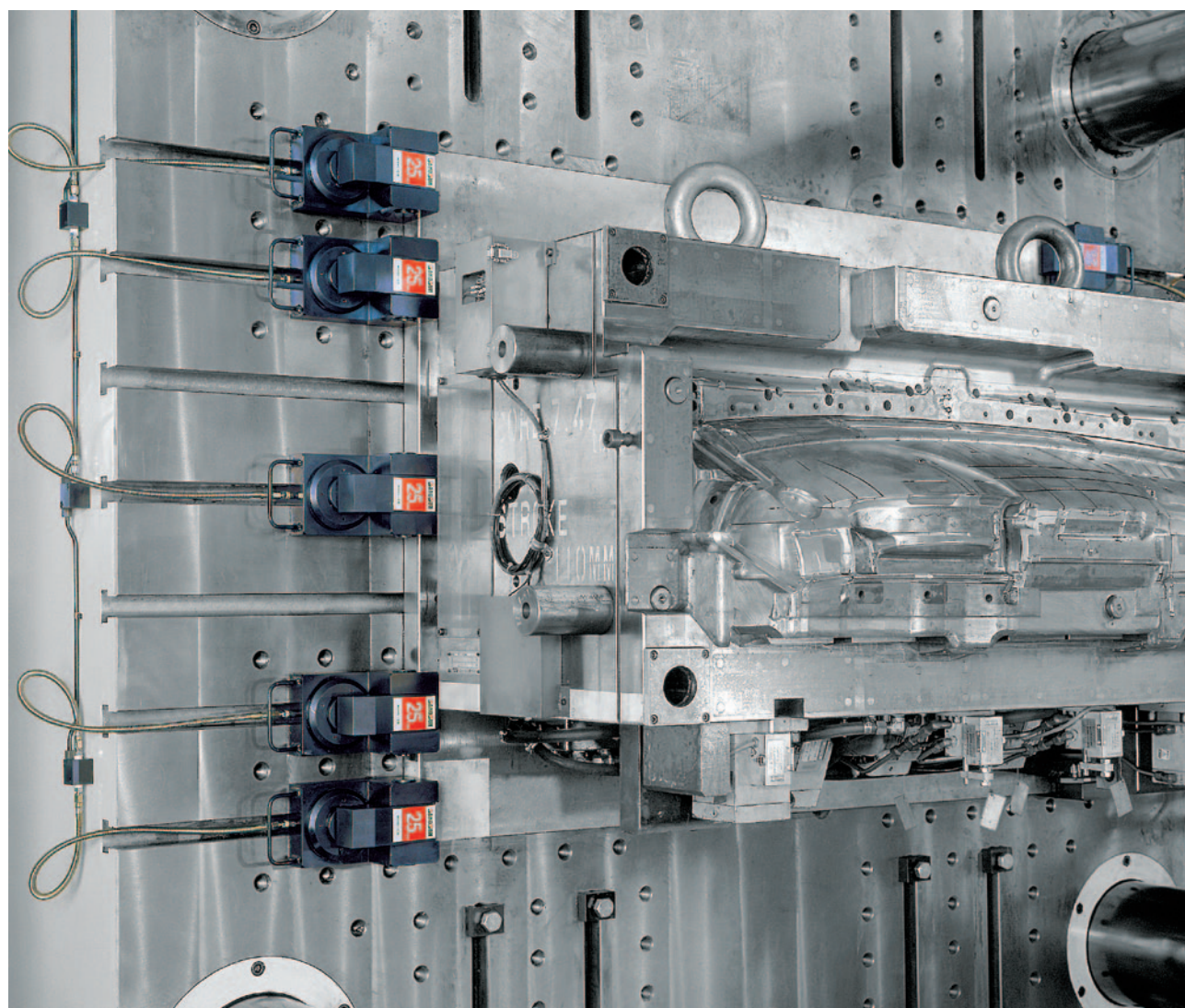

### Safety function of system

- Each hydraulic circuit has the function of checking and avoiding oil leaking.
- This system can add pressure automatically when the pressure reduction.
- Each hydraulic circuit has the function of inspection pressure and can be interlocked with the machine.
- It adopts the intersecting direction to clamp the mold.
- There are several functions to avoid operation error.

### 系統安全功能

- 各油壓迴路具有逆止防漏功能。
- 此系統具壓降時自動補壓功能。
- 各油壓迴路具低於安全壓力檢知功能，並與機台連線。
- 夾模採對角交叉方向鎖模控制。
- 操控具多項防呆功能。

## 快速換模 / 台車系統

迎接少量多樣高頻率換模生產型態的時代，爭取換模時效、確保操作安全—正是導入快速換模系統的最佳時機。

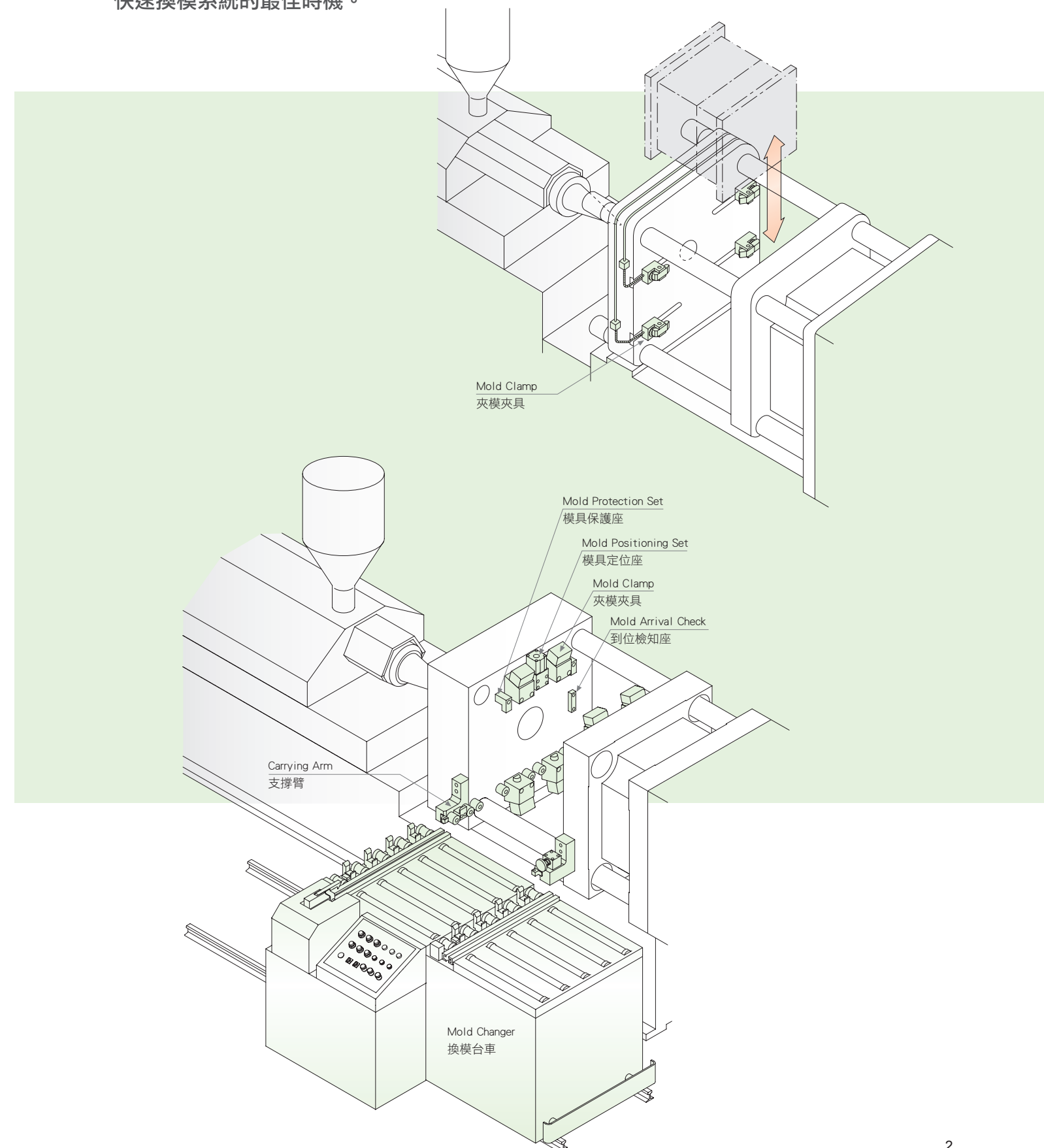



- The hydraulic pump is driven by air. Once the outlet hydraulic pressure reaches the setting pressure, it will stop pumping which won't waste any energy. The pressure would be added automatically if the outlet pressure is reducing. It consists of the function to keep the pressure continuously.
- 利用空氣壓力驅動泵浦，出口油壓達設定壓力即停止作動不需繼續消耗能源，出口壓力下降則自動補壓，具持續保持該壓力功能。

Model Selection 型式選定

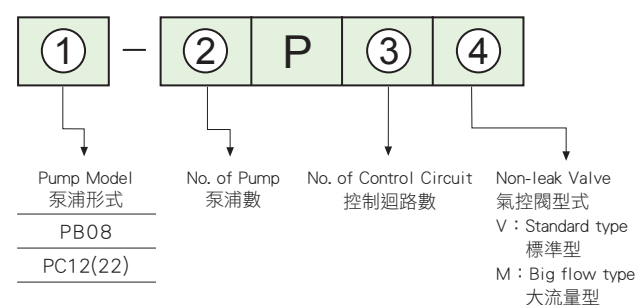

Outline Dimensions 外型尺寸

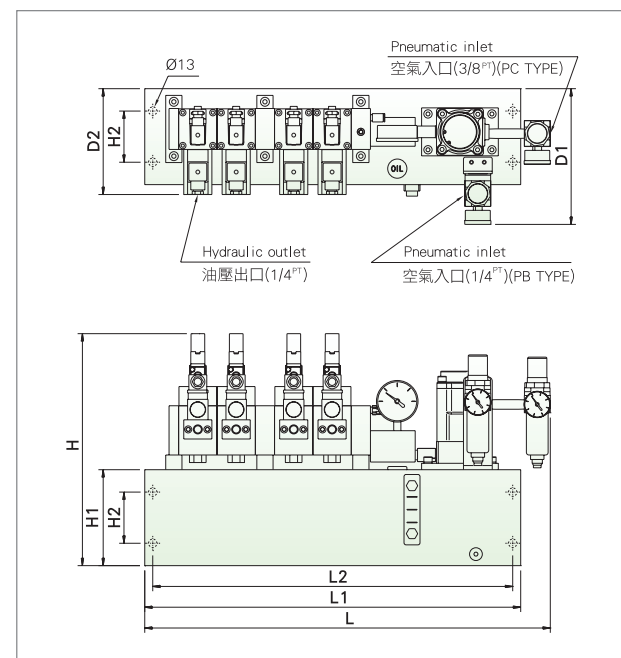

MODEL 型式	L	L1	L2	H	H1	H2	D1	D2	V
PB08-1P4V	-	588	563	367	150	80	235	-	10/
PC12-1P4V	650	588	563	367	150	80	-	175	10/
PC12-1P4V	650	588	563	417	200	80	-	225	17/
PCC1222-2P4M	990	868	843	417	200	80	-	225	27/

● V : Volume of oil tank (Liter) 油箱容量

Discharge Flow Characteristics 吐出量特性圖

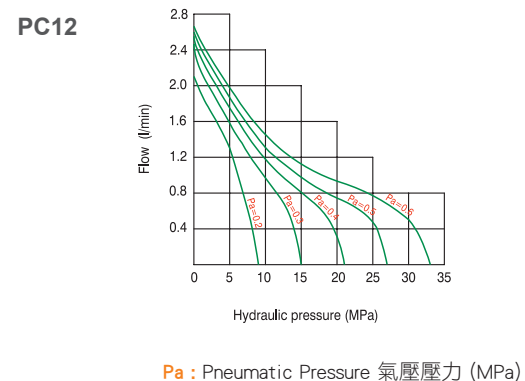
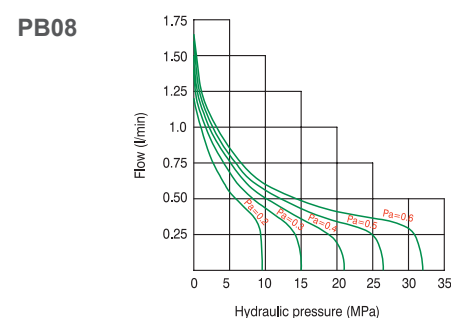

Circuit Control System 迴路控制系統

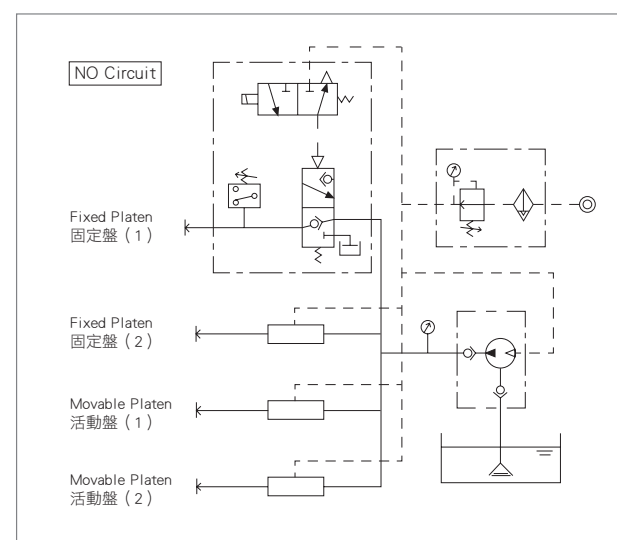

Model Selection 型式選定

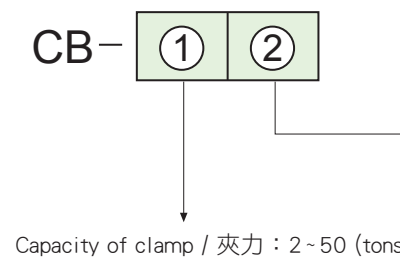

- EMPTY : Standard type 無：標準式
- N : With sensor type 附近接開關 DC10~30V (NPN, 3-Wire)
- C : Pneumatic cylinder movable type 氣缸移動式
- B : Fixed type 固定式
- S : Slide movable type 導座式
- V : Heat-resistant type 耐高溫式 (無護蓋)
- VR : Heat-resistant with cover type 耐高溫式 (加護蓋)

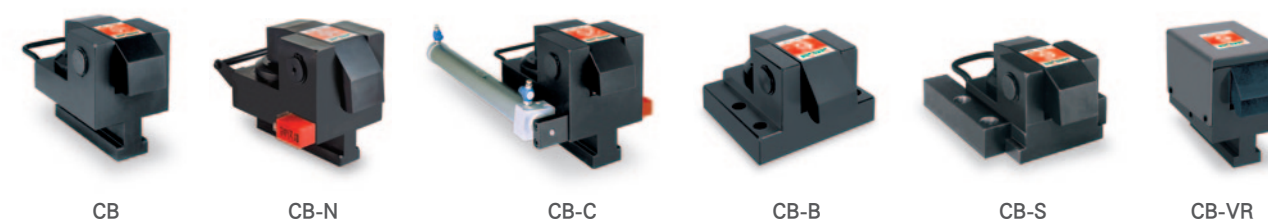

Instruction of Specification 規格說明

MODEL 型式	CB-2	CB-4	CB-6	CB-10	CB-16	CB-25	CB-50
Capacity of clamp 夾力 * tons	2	4	6	10	16	25	50
Total stroke (X) 總行程 (X) mm	8	8	8	8	8	8	10
Stroke of clamp (Y) 夾具行程 (Y) mm	3	3	3	3	3	3	4
Preserved stroke (Z) 預留行程 (Z) mm	5	5	5	5	5	5	6
Total volume of cylinder 油缸總容量 cc	7.5	13	21	38	55	98	220
The tolerance of the template thickness (H) 模板厚度允許公差 : (H) mm	±2	±2	±2	±2	±2	±2	±2

\* Hydraulic Pressure 使用油壓壓力：24.5MPa (250kg/cm<sup>2</sup>) (3550psi)

Selection of System Components 選用規範

MACHINE TONS 機台噸數	CLAMP 夾具	NO. OF CLAMP 夾具數量	PUMP UNIT 泵浦單元	HEIGHT OF TANK 油箱高度
100~150	CB-2	8	PB08-1P4V	150
150~250	CB-4	8		
280~350	CB-6	8		
380~550	CB-10	8		
550~850	CB-16	8		
850~1300	CB-16	12	PC12-1P4V	150
1300~1600	CB-25	8		
1800~2500	CB-25	16	PCC1222-2P4M	200
2600~3200	CB-25	20		
3300~4000	CB-50	12		
3300~4000	CB-50	16		

\* If machine over 4000T, will planning customized. 機台噸數4000噸以上，依機台狀況客製化規畫。



## CLAMP OUTLINE / DISTRIBUTION 夾具外型 / 配置

### Model CB

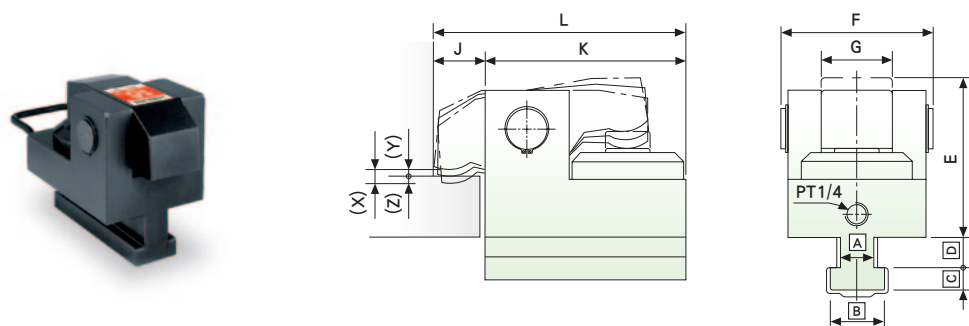

#### Outline Dimensions 外型尺寸

Unit : mm

MODEL 型式	L	K	J	min. E	F	G	min. C
CB-2	110	90	20	73	68	32	10
CB-4	134	110	24	77	79	40	12
CB-6	159	130	29	92	96	46	14
CB-10	189	159	30	114	117	54	16
CB-16	230	200	30	126	129	58	20
CB-25	265	235	30	148	156	70	23
CB-50	320	290	30	180	246	110	34

- The size of clamps **A** **B** **C** and **D** are made based on the size of T-slot.
- 夾具 **A** **B** **C** **D** 尺寸係配合T槽尺寸製作。

#### Vertical Loading / 上方換模

Platen with T-slot  
台盤有T型槽

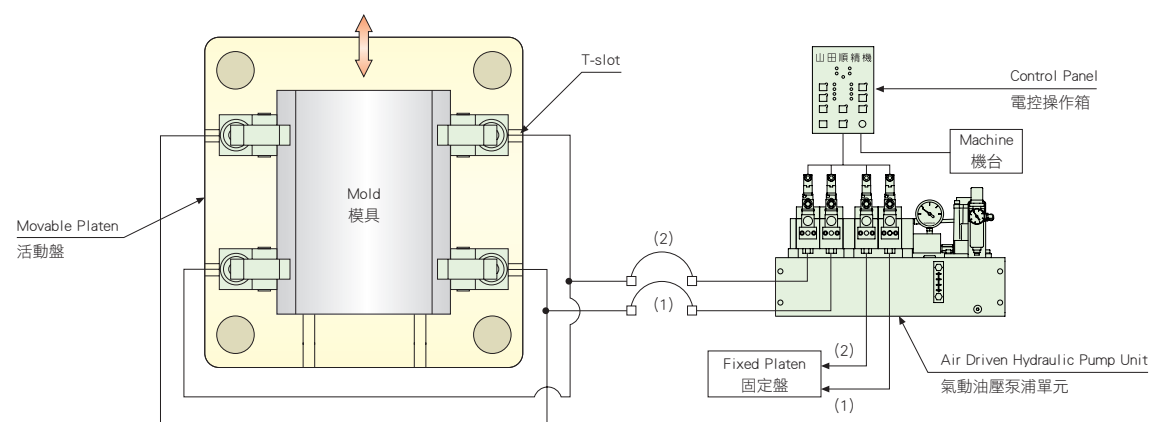

- Optional for position checking sensor 可選配定位檢知配備

### The Requirement of Mold Dimension / 模具配合尺寸

#### Flange Type of Mold 模具標準型

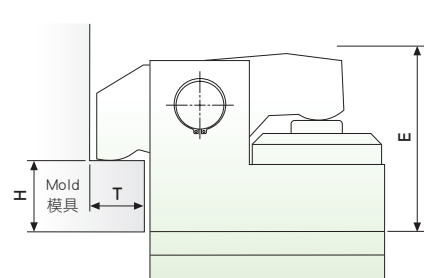

Unit : mm

MODEL 型式	E	T	H
CB-2	73	20	25
CB-4	77	24	25
CB-6	92	29	30
CB-10	114	30	40
CB-16	126	30	40
CB-25	148	30	45
CB-50	180	30	60

- The dimension is as minimum. 左側尺寸為min.
- If  $H < \text{min}$  size, it needs special design.  $H$  如小於左述尺寸需特殊設計
- The template thickness :  $H \pm 2\text{mm}$  模板厚度 :  $H \pm 2\text{mm}$

### Model CB-N

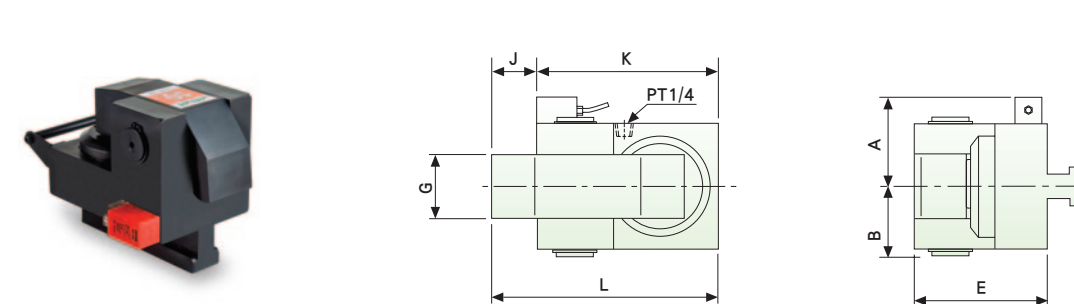

#### Outline Dimensions 外型尺寸

Unit : mm

MODEL 型式	A	B	min. E	G	J	K	L
CB-2N	48	34	73	32	20	90	110
CB-4N	61.5	39.5	77	40	24	110	134
CB-6N	70	48	92	46	29	130	159
CB-10N	80	58.5	114	54	30	159	189
CB-16N	86	64.5	126	58	30	200	230
CB-25N	99	78	148	70	30	235	265
CB-50N	144	123	180	110	30	290	320

#### Vertical Loading / 上方換模

Platen with T-slots and manual clamp equipped with sensor.  
台盤有T型槽，夾具加裝近接開關檢知

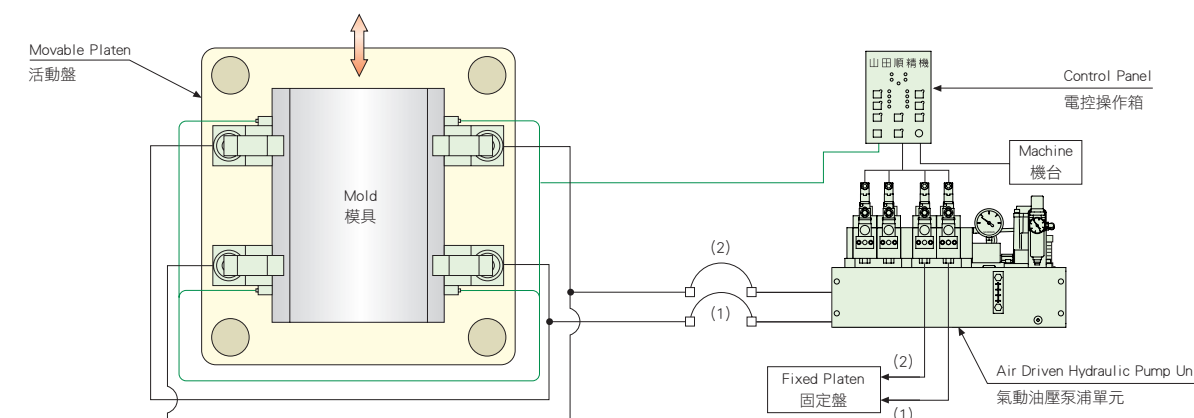

### The Requirement of Mold Dimension / 模具配合尺寸

#### Concave Type of Mold 模具凹入型

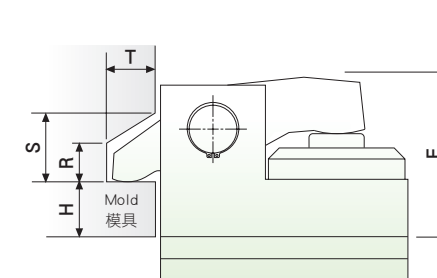

Unit : mm

MODEL 型式	R	S	T	H	E
CB-2	18	30	20	35	83
CB-4	18	32	24	35	87
CB-6	20	38	29	40	102
CB-10	22	40	30	50	124
CB-16	30	47	30	50	136
CB-25	45	62	30	50	160
CB-50	52	70	30	60	180

- The dimension is as minimum. 左側尺寸為min.
- If  $H < \text{min}$  size, the size of R and S need to be changed.  $H$  如小於左述尺寸則R·S尺寸需更改
- The template thickness :  $H \pm 2\text{mm}$  模板厚度 :  $H \pm 2\text{mm}$

## CLAMP OUTLINE / DISTRIBUTION 夾具外型 / 配置

### Model CB-C

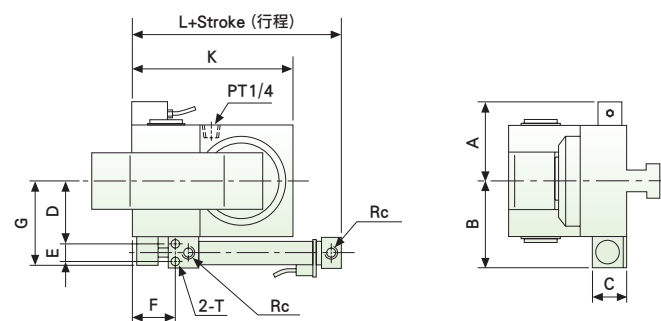
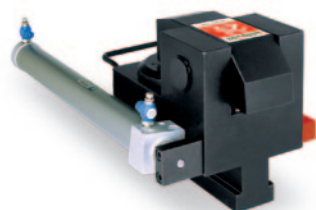

### Outline Dimensions 外型尺寸

Unit : mm

MODEL 型式	A	B	C	D	E	F	G	K	L	Rc	Tapping(T) 台盤加工
CB-2C	48	68	28	41	20	57.5	66	90	131	1/8	M6×12D
CB-4C	61.5	73.5	28	46.5	20	57.5	71.5	110	131	1/8	M6×12D
CB-6C	70	86	34	55	24	61.5	82	130	135	1/8	M6×12D
CB-10C	80	104	40	66	30	48.5	101	159	129	1/8	M8×16D
CB-16C	86	119.5	50	73.5	36	50	117	200	141	1/8	M10×20D
CB-25C	99	133	50	87	36	50	130	235	141	1/8	M10×20D
CB-50C	144	261	100	138	110	62	219	290	192	3/8	M16×32D

### Vertical Loading / 上方換模

Platen with T-slots and clamps moved automatically by pneumatic cylinder  
台盤有T型槽，夾具採氣缸自動進退

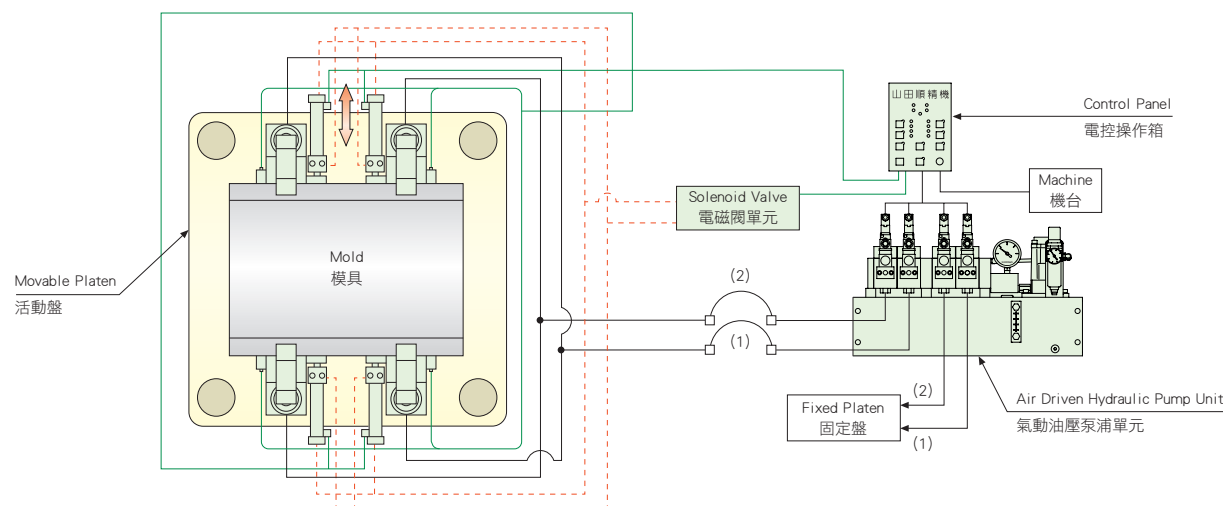

• Another selection of clamping direction : left-right 可改為左右方向夾模

## POWER CONTROL PANEL 動力控制箱



1. This panel is applied to clamp CB-C type.
2. Distribution of panel :
  - Air driven hydraulic pump unit.
  - Air solenoid valve unit.

1. 夾具採CB-C型時，搭配此控制箱。
2. 控制箱配置：
  - 氣動油壓泵浦單元。
  - 氣壓電磁閥單元。

### Model CB-S

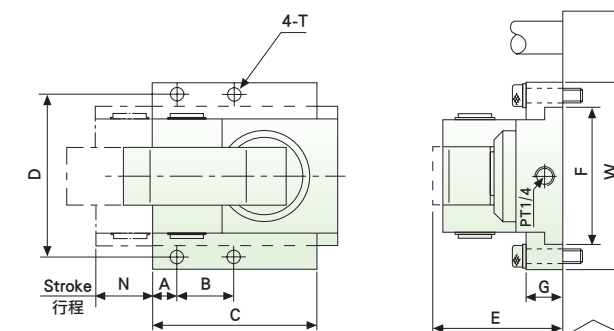

### Outline Dimensions 外型尺寸

Unit : mm

MODEL 型式	A	B	C	D	min. E	F	G	W	max. N	Tapping(T) 台盤加工
CB-2S	12	20	80	98	90	76	30	124	25	M10×20D
CB-4S	12	25	100	109	93	87	30	135	30	M12×24D
CB-6S	15	30	120	126	109	104	30	152	35	M12×24D
CB-10S	15	35	150	148	131	124	36	174	40	M14×28D
CB-16S	20	40	200	166	142	138	44	200	50	M18×36D
CB-25S	20	50	235	200	163	168	48	240	60	M22×45D

### Vertical Loading / 上方換模

For Platen without T-slots and the sizes of mold are variable.  
台盤無T型槽，模具尺寸不統一

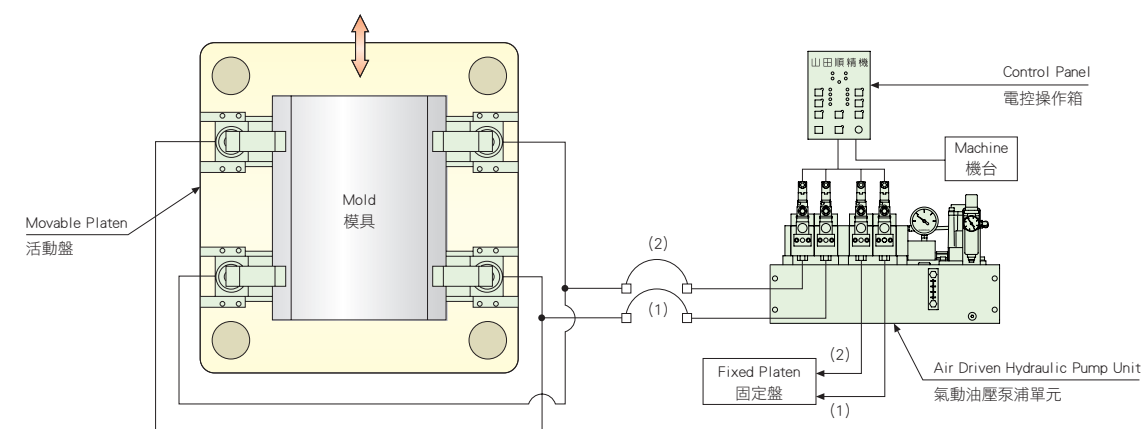

## Suggested Dimension of T-slot / Additional T-slots Platen T型槽 / 附加台盤建議尺寸

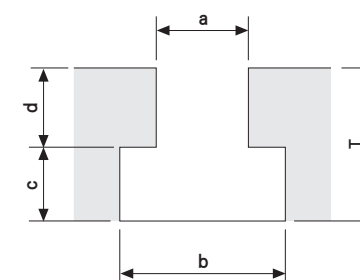

	T	a	b	c	d
CB-2	32	18	32	14	18±0.2
CB-4	40	22	37	16	24±0.2
CB-6	40	22	37	16	24±0.2
CB-10	44	28	48	18	26±0.2
CB-16	52	28	48	22	30±0.2
CB-25	61	36	56	25	36±0.2
CB-50	84	48	80	36	48±0.2

• T : the thickness of additional T-slot platen (min.) 附加台盤最小厚度

## CLAMP OUTLINE / DISTRIBUTION 夾具外型 / 配置

### Model CB-B

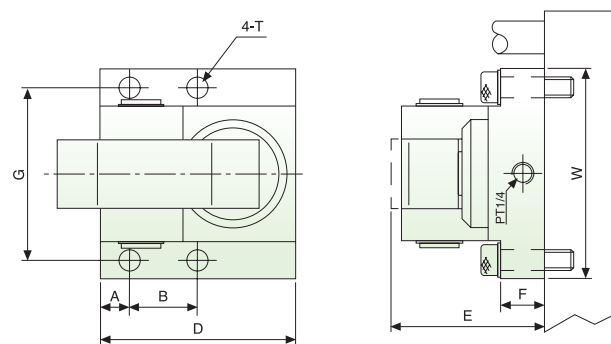

Unit : mm

### Outline Dimensions 外型尺寸

MODEL 型式	A	B	D	F	G	min. E	W	Tapping(T) 台盤加工
CB-2B	12	35	90	20	84	90	106	M10×20D
CB-4B	12	40	110	25	95	93	117	M12×24D
CB-6B	15	45	130	30	115	109	140	M12×24D
CB-10B	15	55	159	30	135	131	160	M14×28D
CB-16B	20	65	200	30	158	142	192	M16×32D
CB-25B	20	80	235	30	184	163	218	M18×36D

### Vertical Loading / 上方換模

For Platen without T-slots and the sizes of mold is unified.  
台盤無T型槽，模具尺寸統一

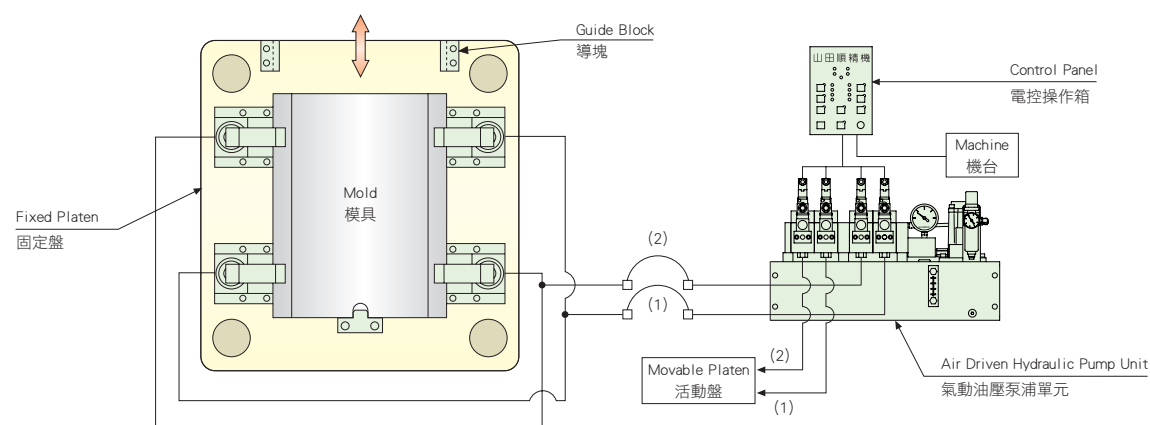

• Suggest CB-S for movable platen 活動盤建議搭配CB-S型使用

### Accessories / 相關配件

Air Driven Hydraulic Pump  
氣動油壓泵浦

Non-leak Valve  
氣控閥

Pump cover  
泵浦護罩



### Model CG

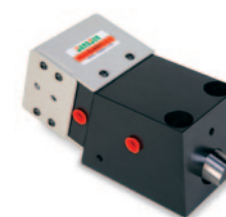

- CG Clamp is characterized in mechanical locking system. The holder of clamp can be shrunk into the clamp when unclamping. It can avoid interference between the holder and mold template.
- It is only applied on Mold Changer System.
- CG 夾具具有自鎖機構之特性，壓板可縮入夾具本體內。能避免開模時壓板與模具底板間的干涉。
- 此型只適用於搭配換模台車使用。

### Model Selection 型式選定

CG-① B-②-③-④

- The capacity of clamp (4-50 ton) / 夾具能力
- Thickness of template (H±0.5mm)  
模板厚度 (允許公差: H±0.5mm)
- The direction of piping and wiring connection  
配管、配線接續方向  
L: on the left side (as below drawing) / 在左側 (如下圖示)  
R: on the right side / 在右側  
U: on the upper side / 在上方
- Sensor voltage / 近接開關使用電壓  
3: DC10~30V (NPN, 3-Wire)  
4: DC10~30V (PNP, 3-Wire)

### Instruction of Specification 規格說明

Unit : mm

MODEL 型式	CG-4B	CG-6B	CG-10B	CG-16B	CG-25B	CG-50B
Clamping force 夾力 * tons	4	6	10	16	25	50
Retaining force 保持能力 * tons	0.8	1.2	2	3.2	5	10
Preserved stroke (Z) 預留行程 (Z) mm	1.5		2			
Working temperature 工作溫度 °C	Max 70°C					

\* Hydraulic Pressure 使用油壓壓力: 13.7MPa (140kg/cm<sup>2</sup>) (2000psi)

\* No hydraulic pressure 在零壓力時

### CG-4B~10B

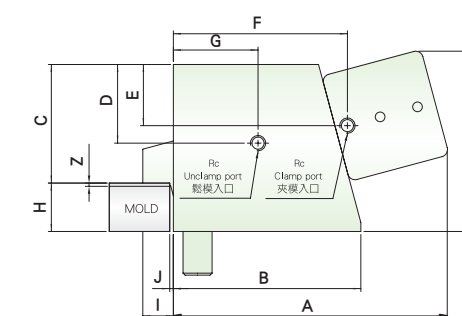
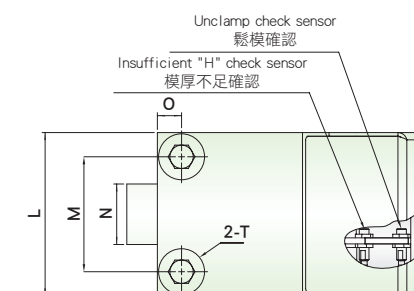

### CG-16B~50B

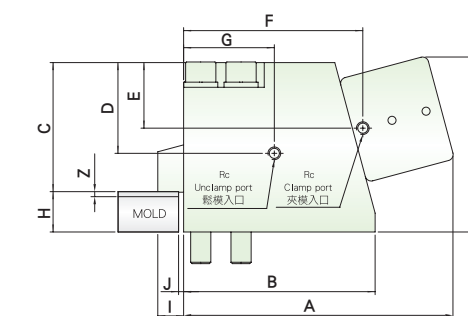
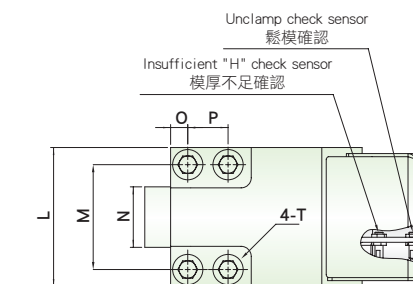

Unit : mm

MODEL 型式	A	B	C	D	E	F	G	I	J	L	M	N	O	P	Q	Rc	H±0.5	T
CG-4B	186	123	75	50	30	113	42	17	2	90	62	35	14	—	115	1/4	25	M16 x 32D
CG-6B	202	140	85	48	36	126	48	19	3	110	76	45	17	—	124	1/4	30	M20 x 40D
CG-10B	215	150	98	53	42	138	56	23	3	135	95	50	20	—	131	1/4	30	M24 x 48D
CG-16B	258	190	128	74	53	175	82	28	5	138	104	60	17	40	156	1/4	30	M20 x 40D
CG-25B	302	240	159	100	64	212	100	33	5	170	130	75	20	50	188	3/8	40	M24 x 48D
CG-50B	365	290	195	140	88	268	125	35	5	215	162	100	27	60	227	3/8	50	M33 x 65D

• H is the minimum size H為最小尺寸 • When H increases, the size of Q will be increased accordingly H增加時Q尺寸會等值增加





- Feature
  - Better safety design clamp.
  - Clamp with Build-in check valve, it can keep the pressure itself.
  - The clamp will not release, even if the hydraulic tube is damaged.
  - Separate clamp body design, easy for maintain and exchange.
  - Waterproof design for cylinder and piston.
- 特色
  - 更安全的夾具設計。
  - 夾具內建逆止閥，可獨立自行持壓。
  - 即使油管爆裂，夾具也不會鬆開。
  - 兩段式本體設計，維修更換本體更為便利。
  - 油缸、活塞防水設計。

Model Selection 型式選定

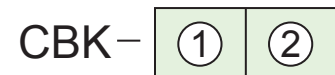

Capacity of clamp / 夾力: 2 - 25 (tons)

- **EMPTY** : Standard type  
無：標準式
- **N** : With sensor type  
附近接開關  
DC10~30V (NPN, 3-Wire)
- **C** : Pneumatic cylinder movable type  
氣缸移動式

Instruction of Specification 規格說明

MODEL 型式		CBK-2	CBK-4	CBK-6	CBK-10	CBK-16	CBK-25
Capacity of clamp 夾力	* tons	2	4	6	10	16	25
Total stroke (X) 總行程 (X)	mm	8	8	8	8	8	8
Stroke of clamp (Y) 夾具行程 (Y)	mm	3	3	3	3	3	3
Preserved stroke (Z) 預留行程 (Z)	mm	5	5	5	5	5	5
Total volume of cylinder 油缸總容量	cc	8	13	22	38	55	99
The tolerance of the template thickness (H) 模板厚度允許公差: (H)	mm	±2	±2	±2	±2	±2	±2

\* Hydraulic Pressure 使用油壓壓力: 24.5MPa (250kg/cm<sup>2</sup>) (3550psi)

Circuit Control System 迴路控制系統

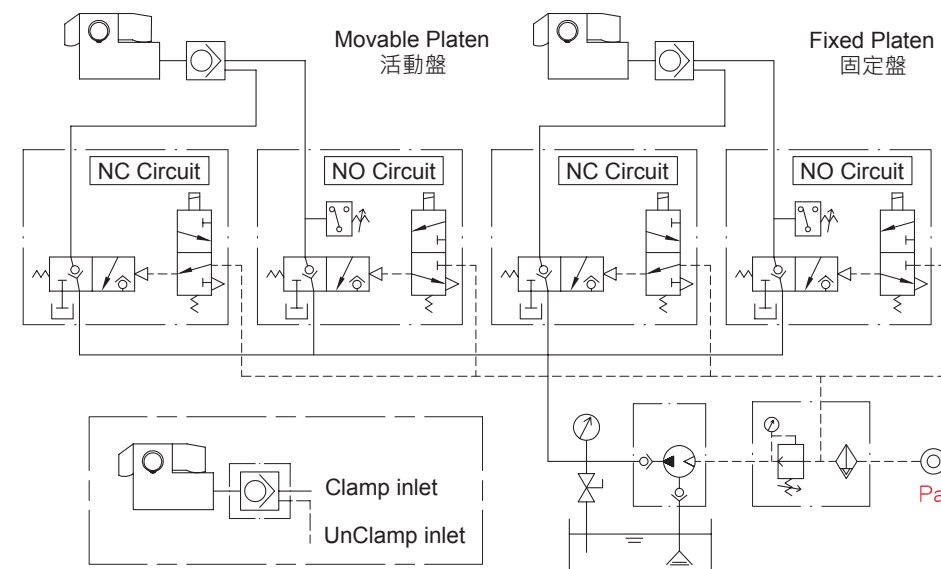

Model **CBK**

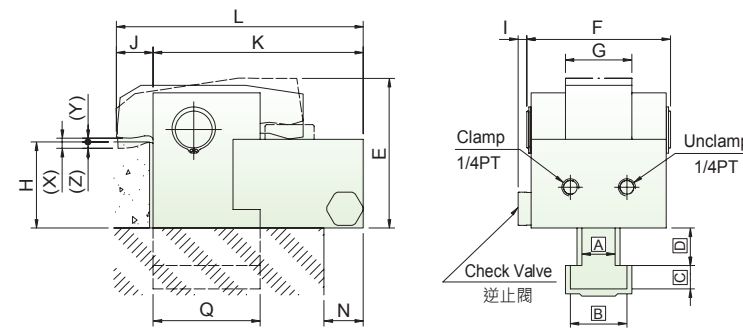

Outline Dimensions 外型尺寸

MODEL 型式	min. C	min. E	F	G	I	J	K	L	max. N	Q
CBK-2	10	73	68	32	9	20	106	126	15	46
CBK-4	12	85	79	40	9	24	124	148	20	61
CBK-6	14	100	96	46	9	29	149	178	25	80
CBK-10	16	119	117	54	8	30	171	201	30	87
CBK-16	20	133	129	58	8	30	202	232	35	108
CBK-25	23	150	156	70	8	30	235	265	40	128

Model **CBK-N**

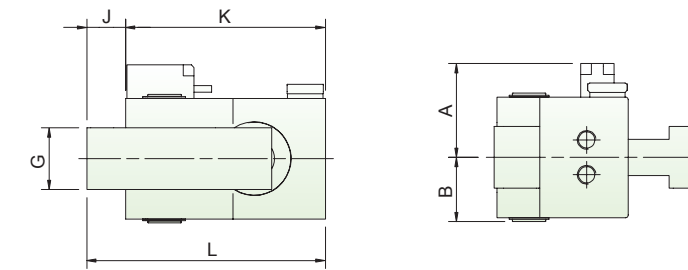

Outline Dimensions 外型尺寸

MODEL 型式	A	B	G	J	K	L
CBK-2N	52	56	32	20	106	126
CBK-4N	57.5	39.5	40	24	124	148
CBK-6N	70	48	46	29	149	178
CBK-10N	80	58.5	54	30	171	201
CBK-16N	85.5	64.5	58	30	202	232
CBK-25N	99	78	70	30	235	265

Model **CBK-C**

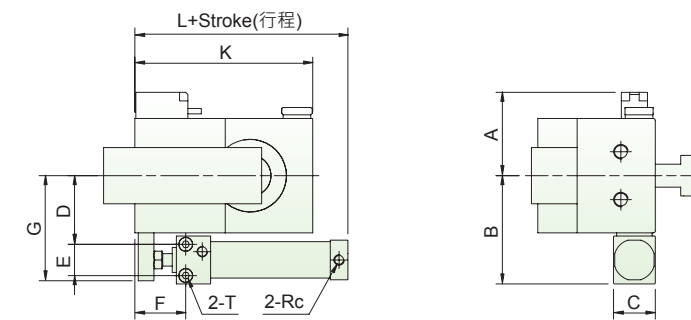

Outline Dimensions 外型尺寸

MODEL 型式	A	B	C	D	E	F	G	K	L	Rc	Tapping(T) 台盤加工
CBK-4C	58	73.5	29	46.5	20	57.5	73.5	124	131	1/8	M6×12D
CBK-6C	70	86	34.5	55	24	61.5	82	149	135.5	1/8	M6×12D
CBK-10C	80	104	41.5	66	30	49	101	171	130	1/8	M8×16D
CBK-16C	86	119.5	52	73.5	36	50	112.5	202	141	1/8	M10×20D
CBK-25C	99	139	63.5	88	40	65	138.5	235	168	1/4	M10×20D

The operating function

- Machine will be stopped automatically in case of operational errors.
- Mold change for single side is functioned with two-way operation only for avoiding operational errors.
- It is equipped with key switch to prevent operational errors.
- During mold changing, it will check the following steps automatically: Injection unit backward, Ejector backward, Manual mode, and Mold close as signal requirement for unclamping. It can avoid operational errors and possible damages.
- When changing molds or malfunction, it will send signals to stop machine opening/closing the mold.
- When the system is not in use, it can be separated from the control of machine. It can prevent clamp from clamping without mold existence and ensure the life time of mold clamp.
- This system adopts inbuilt non-voltage contacts to interlock with machines.

Remark: Please offer the signal contacts when placing order.



操控功能

- 具有誤操作停機保護功能。
- 具有單側換模二道操作防呆功能。
- 裝有鑰匙開關，避免人為誤操作。
- 鬆模時可依機台提供之:手動模式、射座後退、托模後退、關模完成(註)等動作信號作為鬆模條件，避免誤操作造成損傷。

- 5.換模或異常發生時，輸出信號通知機台禁止開關模。
- 6.不使用時可與機台脫離，避免夾具空夾確保夾具壽命。
- 7.與機台連線採用無電壓接點。

(註): 訂購時須告知機台可提供之信號接點。

MOLD FLIP DEVICE 模具翻轉機

Application: Injection molding machine、Blow molding machine、Die casting machine

適用於: 射出機、中空成型機、壓鑄機。

Features:

- Mold flip device could help in flipping the mold and shorten up the operation time of mold repairing and maintenance.
- Mold flip device is driven by electric hydraulic motor and move the mold through hydraulic power. Mold can be turned at any angle.
- Using mold flip device helps to raise work efficiency and avoid accidents at work place.
- If power shuts during mold flip, each hydraulic circuit is designed with the function of checking and avoiding oil leakage and the device will stop at the final stage.

特色:

- 模具翻轉機用於輔助模具翻轉，又可達到縮短模具保養及維修工作時間。
- 模具翻轉機使用電動油壓馬達，以油壓力量翻轉模具。模具可作任意角度翻轉。
- 運用模具翻轉機可提高工作效率又可達到零工安意外。
- 翻轉過程中如發生斷電，各油壓迴路具逆止防漏功能，機台立即停止於最後狀態。

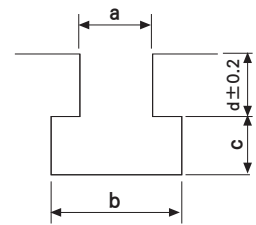

DATA REQUIRED FOR Q.M.C.S. 快速換模系統訂購所需資料

Company 訂購公司												
Machine Type 機台種類	<input type="checkbox"/> Injection molding machine / 射出機 <input type="checkbox"/> Vertical injection molding machine / 直立式射出機 <input type="checkbox"/> Die casting machine / 壓鑄機 <input type="checkbox"/> Blow molding machine / 中空成型機											
Machine Brand 機台廠牌	Capacity 機型噸數	<input type="checkbox"/> New purchased / 新購 <input type="checkbox"/> Existing / 舊機										
Drawing 圖面	<input type="checkbox"/> Machine outline / 機台外型圖 <input type="checkbox"/> Platen drawing / 車壁圖											
Item 項目	Pump unit / 泵浦單元	Mold clamp / 夾模夾具										
Model 型式	Remark / 備註											
Q'ty 數量												
<b>1</b> Control Voltage / 控制電壓： <input type="checkbox"/> AC110V <input type="checkbox"/> AC220V <input type="checkbox"/> DC24V												
<b>2</b> The thickness of template / 模具底板厚度 (H) : _____ mm												
<b>3</b> Mold size / 模具尺寸 : Max : _____ (L) × _____ (W) Min : _____ (L) × _____ (W)												
<b>4</b> Mold type / 模具： <input type="checkbox"/> Flange type / 標準型 <input type="checkbox"/> Concave type / 凹入型 (Please offer the size of concave area / 需提供凹入尺寸) S : _____ R : _____ T : _____												
<b>5</b> Working temperature / 工作溫度 : _____ °C												
<b>6</b> Mold with heating insulation platen / 模具附加隔熱板： <input type="checkbox"/> Yes (Please offer the thickness) / 有 (請提供厚度) <input type="checkbox"/> No / 沒有												
<b>7</b> Clamping direction / 夾模方向： <input type="checkbox"/> Up-Down / 上-下 <input type="checkbox"/> Left-Right / 左-右												
<b>8</b> When the clamping direction is up-down, is there any "Safety platform" ? 夾模方向為上-下時，機台是否有安全踏板? <input type="checkbox"/> Yes (Please offer the installing drawing) / 有 (請提供安裝圖面) <input type="checkbox"/> No / 沒有												
<b>9</b> Platen with other equipment / 台盤加裝其他配置： <input type="checkbox"/> Robot / 機械手 <input type="checkbox"/> others / 其它												
<b>10</b> Please offer the following signal contact. / 請射出機提供以下訊號接點供鬆模確認： <input type="checkbox"/> Injection unit backward / 射座後退 <input type="checkbox"/> Ejector backward / 托模後退 <input type="checkbox"/> Manual mode / 手動模式 <input type="checkbox"/> Mold close / 關模完成 <input type="checkbox"/> No / 沒有												
<b>11</b> T-slot / T槽尺寸：  <table border="0" style="width: 100%;"> <tr> <td>Movable platen / 活動盤</td> <td>Fixed platen / 固定盤</td> </tr> <tr> <td>a : _____</td> <td>a : _____</td> </tr> <tr> <td>b : _____</td> <td>b : _____</td> </tr> <tr> <td>c : _____</td> <td>c : _____</td> </tr> <tr> <td>d : _____ (±0.2)</td> <td>d : _____ (±0.2)</td> </tr> </table> <p>* For existing machine, please offer "d" size with the first decimal digit.          * 舊機請提供d尺寸至小數點第一位。</p>			Movable platen / 活動盤	Fixed platen / 固定盤	a : _____	a : _____	b : _____	b : _____	c : _____	c : _____	d : _____ (±0.2)	d : _____ (±0.2)
Movable platen / 活動盤	Fixed platen / 固定盤											
a : _____	a : _____											
b : _____	b : _____											
c : _____	c : _____											
d : _____ (±0.2)	d : _____ (±0.2)											
<b>Others 其他</b> CE certificated required / 產品是否須CE認證 <input type="checkbox"/> Yes / 需要 <input type="checkbox"/> No / 不需要 Installation by Sandsun / 山田順需安裝 <input type="checkbox"/> Yes / 需要 <input type="checkbox"/> No / 不需要												

DATA REQUIRED FOR M.C.S. 換模台車系統訂購明細資料

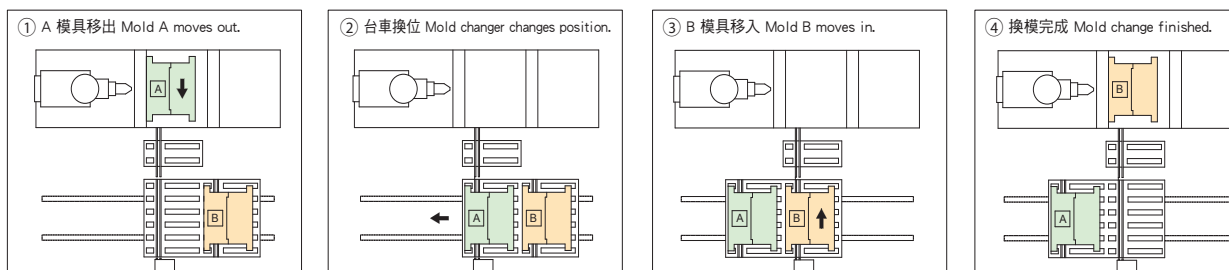
Company 訂購公司		Quantity 數量
Machine Brand 機台廠牌		Capacity 機型噸數
<b>1</b> Mold changer type / 台車所需型式： <input type="checkbox"/> Single machine and mold / 單機單模 <input type="checkbox"/> Single machine and twin molds / 單機雙模 <input type="checkbox"/> Twin machines and molds / 雙機雙模 <input type="checkbox"/> Multi-machines and twin molds / 多機雙模		
<b>2</b> The way of mold movement / 模具移動方式： <input type="checkbox"/> Hook push-pull / 掛鈎推拉 ( <input type="checkbox"/> Fixed hook set / 鈎模座固定 <input type="checkbox"/> movable hook set / 鈎模座移動) <input type="checkbox"/> Motor driven roller / 滾輪 <input type="checkbox"/> _____		
<b>3</b> Main power supply / 動力電源： <input type="checkbox"/> AC 220V <input type="checkbox"/> AC 380V <input type="checkbox"/> AC _____ V (3Ø4W) <input type="checkbox"/> 60 Hz <input type="checkbox"/> 50 Hz		
<b>4</b> Rail track construction / 台車行走軌道： <input type="checkbox"/> Buried under ground / 埋入式 <input type="checkbox"/> On the ground / 安裝地面 <input type="checkbox"/> On the bench / 台架上		
<b>5</b> Rail track length / 行走軌道長度： <input type="checkbox"/> Min. length for mold changing / 最小換模距離 <input type="checkbox"/> _____ mm		
<b>6</b> Operation / 操作方式： <input type="checkbox"/> Total automation / 全自動 <input type="checkbox"/> Manual / 手動		
<b>7</b> Brand of parts such as sensor, motor / 零件廠牌： <input type="checkbox"/> Mostly made in Taiwan / 台製品牌為主 <input type="checkbox"/> Other requirement / 其它：_____		
<b>8</b> Mold specifications / 模具規格： Max. mold weight / 模具最大重量 : _____ ton H1 : _____ mm (Fixed side / 固定側) H2 : _____ mm (Movable side / 活動側) W : _____ mm W1 : _____ mm Z : _____ mm L : Min : _____ mm Max : _____ mm D : Min : _____ mm Max : _____ mm		
<b>9</b> Mold working temperature / 模具工作溫度 : _____ °C		
<b>10</b> Mold position / 定位裝置 : <input type="checkbox"/> Yes (Please offer drawing) / 有 (提供定位圖面) <input type="checkbox"/> No. / 無		
<b>11</b> The height of nozzle center to ground / 射嘴中心到地面高度 : _____ mm		
<b>12</b> Heating insulation platen / 隔熱板 : <input type="checkbox"/> Yes (Please offer drawing and thickness) / 有 (提供板厚及外型圖) <input type="checkbox"/> No. / 無		
Remark 備註 : 1. Size (W), (W1), and (H) needs to be standardized. 尺寸W, W1 及H 需規格化。 2. There must be positioning device. 必須有定位裝置(如無時, 需配合加工)。 3. It is not allowed to heat the mold on MCS. 禁止於台車加熱模具。 4. IMMS has to be fixed on the ground with construction. 射出機須做土木工程固定於地面。		
<b>Technical Data 技術資料</b>		
<b>Mold changer system-Mold changing procedures / 換模台車-換模流程圖：</b>		
		

MOLD CHANGER SYSTEM 換模台車系統



Feature

1. Shorten the operation time of mold change.
2. Auto position checking of mold changer moving.
3. Automatically check the stroke of mold open, arrival and positioning in the process of mold move-in.
4. Device for preventing mold sliding.

Multi-machines in one line (fixed hook set) 多機直列 (鈎模座固定)

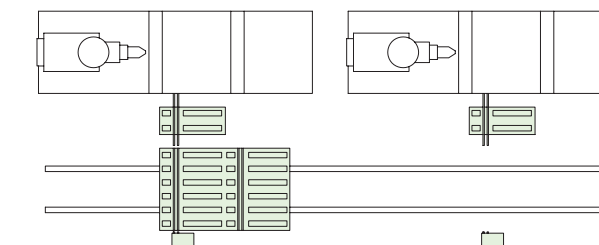

Multi-machines in one line (movable hook set) 多機直列 (鈎模座移動)

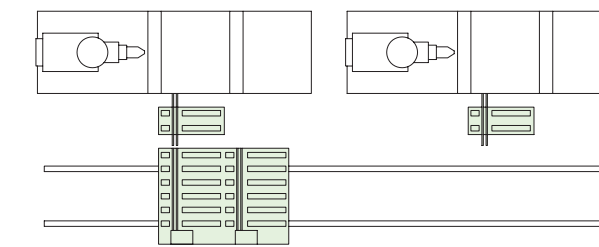

Multi-machines juxtaposed / 多機並列

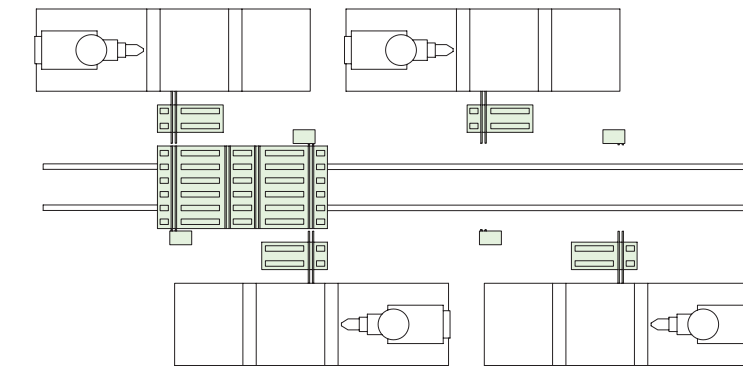

特色

1. 減少換模待機時間。
2. 台車移動自動對機台尋位。
3. 模具移入自動檢知開模行程、到及定位裝置。
4. 模具滑落防呆保護裝置。

Single machine and mold / 單機單模

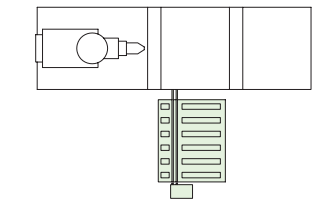

Single machine and twin molds (fixed hook set) 單機雙模 (鈎模座固定)

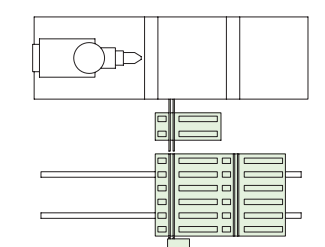

\* Customers are required to finish the following things before Mold Changer System installation.

1. Rail construction.
2. Standardize the mold template.
3. Process the mold positioning slot, the hole of fixed plate for hook set, and mold template chamfering.

\* 裝機前客戶需完成以下事項

1. 軌道埋設工程。
2. 模具底板規格化。
3. 模具定位槽、拉模座孔位、模板倒角加工。